



CAR FILLING



DISPENSERS



PUMPS



METERS



NOZZLE METERS



NOZZLES

3D FILTER

FEATURES

- 3-STEP FILTRATION
- HI-RESISTANCE CASE
- REMOVABLE CARTRIDGE

The Piusi 3D FILTER is specifically designed to prevent the contamination of AdBlue® during transferring operation. Thanks to the highly efficient (200) mechanical filtration, it allows an extended life of the catalyst.

PERFORMANCE

200 β

FILTERING CAPACITY

**UP TO
4 BAR**

OPERATING PRESSURE



3D FILTER



PACKAGING

CODE	WEIGHT			PACKAGING		
	A MM.	B MM.	C MM.	WEIGHT KG.	DIMENSION MM.	FILTER HEAD PCS/BOX
FOO611DOO	136	107	140	0,6	200X120X140	166X144X85
FOO611D1A	104	70	104	0,2	166X144X85	-



FILTRATION



FLUID MONITORING



HOSE REELS



ACCESSORIES



MERCHANDISE

INDEX



AIR



ANTIFREEZE



AdBlue®



BIODIESEL



DIESEL



FOOD



GASOLINE



GREASE



KEROSENE



OIL



WATER



WINDSCREEN

FUNCTIONING



Typical condition of the filter after 30.000 liters dispensed. We recommend changing the filter cartridge once a year.

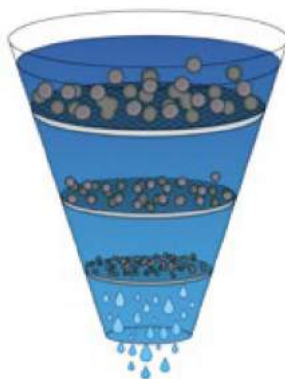

High efficiency (β 200) mechanical filtration of particulate by means of an incremental filter specifically developed for AdBlue®.

IN THE BOX

- 3D FILTER
- INSTRUCTION MANUAL

DETAILS



A3D FILTER CARTRIDGE

DIMENSIONS

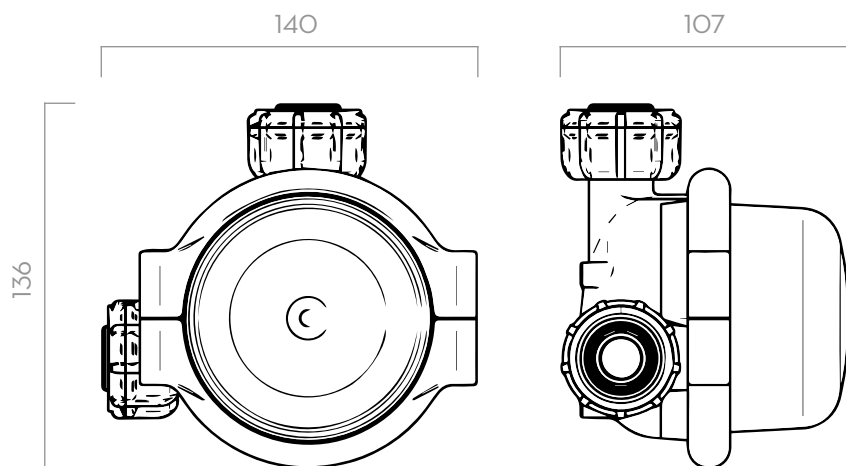

Dimensions expressed in millimeters

MATERIALS

- BODY: TECHNOPOLYMER
- CARTRIDGE: POLYPROPYLENE

TECHNICAL DATA

CODE	DESCRIPTION	FLUIDS TYPE	FLOW-RATE		INLET/OUTLET	WATER ABSORBING	EFFICIENCY	MICRO	PRESSION
			L/MIN	GPM					
FOO611D00	3D FILTER FOR ADBLUE		40	10,5	1"	-	200	70	4
FOO611D1A	3D FILTER CARTRIDGE		-	-	-	-	-	-	-

3D FILTER