

Small Filter Housings

VF-609

Clean Dry Fuels with High Performance

Aquacon[®] Filter Cartridges for Helicopter Refueling and Dispensing Pumps

FEATURES

- Positive Water Removal – Aquacon cartridges remove free and emulsified water from fuels
- Positive Water Holding – filtered water is chemically locked in and can't be squeezed out
- Pressure Increase signals cartridge change
- Effective Dirt Removal – 98% + efficiency for 1/2, 5, or 25 micrometer particles

APPLICATIONS

- Jet Fuel
- Avgas



The VF-609 uses high performance **Aquacon** filter cartridges. Model above is shown without optional gauge.

NOTE: For non-EI qualified applications. Housing does not meet EI1596 or EI1581 qualifications.

DESCRIPTION

The VF-609 is a versatile filter housing with bolted cover, designed for use with several different high performance **Aquacon** filter cartridges. Refer to the cartridge selection table on the reverse side.

Aquacon cartridges filter out water by chemically locking it into layers of super-absorbent media. Water removal efficiency is not affected by surfactants or additives, and once captured, the water cannot be squeezed out. Water capacity is as much as 1½ quarts, depending on the flow rate. These cartridges also effectively filter out

dirt, rust and other particulates.

As a cartridge reaches its water-holding limit, the media expands very rapidly and restricts the flow. For fuels, the flow will completely stop, giving positive shut-off and guaranteeing water will not get downstream. For oils and other high viscosity liquids, the pressure drop will rapidly increase, signaling the need to change cartridges.

OVER PRESSURE PROTECTION

When exposed to a high concentration of water, the differential pressure across an **Aquacon** cartridge will

immediately increase. Pressure bypasses or other means to limit the inlet pressure to 75 psi (5 bar) should be installed to prevent the cartridge from collapsing.

CAUTION

To protect the fuel system, including the VF-609 and other components, be sure to install pressure relief valve(s).

Do not use **Aquacon**[®] absorbent cartridges (ACO or AD Series) with pre-mixed jet fuel containing anti-icing additives, or with gasoline/alcohol blends.

DIMENSION:

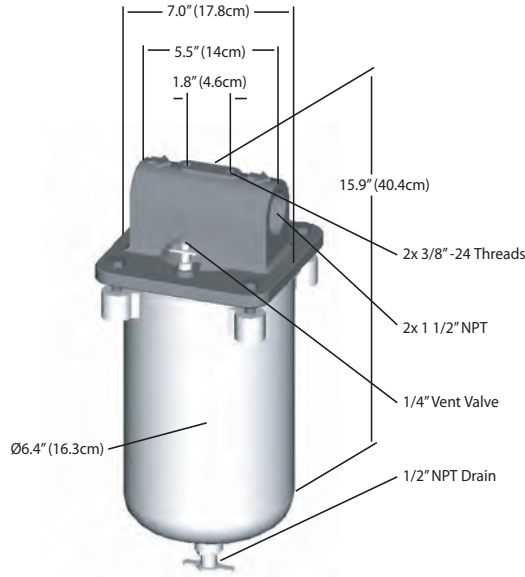

Dimensions are shown for estimating purposes only.

SPECIFICATION:

Housing

- Max. Operating Pressure: 150 psi
- Cast aluminum head; carbon steel shell with TGIC-polyester coated exterior and interior; four bolt head
- Inlet/Outlet Connections: 1 1/2" NPT
- Closure Seal: Buna-N O-Ring – P/N G-0565
- Weight: 8 lbs.
- Shipping Weight: 10 lbs
- 1/4" brass petcock vent valve and 1/2" drain valve
- Bolted cover

ORDERING INFORMATION

- VF-609 unit is supplied with G-0565 Buna-N O-Ring and 1/4" vent valve and 1/2" drain valve.
- Cartridges are not supplied and must be ordered separately.
- Viton O-Rings (P/N G-0565A) are recommended for gasoline and solvent applications.
- Optional Differential Pressure Gauge Assembly is P/N 07-224.
- Optional mounting block for gauge, PN 07-224AMB.
- Optional Drain Valve Part Number 554Y020 is a Carbon Steel 1/2" NPT Ball Valve, with Mounting nipple.

RECOMMENDED SPARES:

- 1 each G-0565 Buna-N O-Ring (or 2 each G-0565A Viton O-Rings)
- 6 each cartridges

Cartridges

- Max. Operating Temp.: 250°F (121.1°C)
- Collapse Strength: 75 psi (5bar)
- pH Range: 5 - 9
- Nom. Filtration Efficiency: 98%

OPTIONAL PRESSURE GAUGE



The VF-609 gauge is an easy to install optional accessory.

Color	Indicates	Pressure Drop
Green	Clean	0 - 15 psi
Yellow	Change	16 - 25 psi
Red	Dirty	26+ psi

FILTER CARTRIDGE SELECTION

Product being filtered	Application	Cartridge P/N	Data Sheet	Type	Micron (µm)	Flow Rate (GPM)
Jet Fuel & Avgas ⁽¹⁾	Dirt & Free water	ACO-609P3R	1681	Aquacon®	0.3	15-36
		ACO-60901R			0.5	
		ACO-60905R			5	
		OS-60988	1858	Coalescer/ Separator	0.5	Jet: 5-35 Avgas: 5-45

(1) Always install a differential pressure gauge or other means of determining differential pressure.